

ADDENDUM NO. 3

VILLAGE OF UNION CITY Sanitary Sewer Rehabilitation Phase V August 2, 2019

To: Planholders

From: Mote & Associates, Inc. Phone: (937) 548-7511
214 West Fourth Street Fax: (937) 548-7484
Greenville, Ohio 45331 E-mail: info@moteassociates.com

Re: Village of Union City
Sanitary Sewer Rehabilitation Phase V

This Addendum forms a part of the Contract Documents and modifies the original Contract Documents dated July 2019, Addendum #1 dated July 29, 2019, and Addendum #2 dated August 2, 2019. Acknowledge receipt of this Addendum in the space provided on the Bid Proposal Form. Failure to do so may subject the Bidder to disqualification.

CHANGES/CLARIFICATIONS TO THE BIDDING DOCUMENTS:

1. ADVERTISEMENT FOR BIDS, SECTION 00 11 13

The time for the opening of the Bids has been extended to Thursday, August 15, 2019 at 1:00 PM (local time). The bid opening will take place at the Village of Union City Office, 419 East Elm Street, Union City, Ohio

2. INSTRUCTIONS TO BIDDERS, SECTION 00 21 13

- A. Article 6 – Pre-Bid Conference shall be changed to state that questions will be received through August 10, 2019 by emailing Heath Riffell at hriffell@moteassociates.com. Any information provided from questions received will be clarified through an Addendum to be issued no later than August 12, 2019.
- B. Article 9 – Contract Time shall be changed to substantially completing the work by December 31, 2020.
- C. Article 10 – Liquidated Damages shall be changed to state that provisions for failure to meet Substantial Completion are \$500.00 per calendar day.
- D. Article 26 – Engineer’s Estimate has been changed to \$480,800.00 for the Base Bid as reflected in the “Revised Bid Form” attached.

3. BID FORM, SECTION 00 41 43

A. A “Revised Bid Form” is attached and shall be utilized with the Bid Package. Changes to this document include, but are not limited to the following:

1) The Base Bid will include the following project items and locations:

- Division Street – Cured-in-Place 12” sanitary sewer pipe from Manhole F32 to E18 for a total length of 1,507 L.F. (Sheet #4 of 7)
- Division Street & Trunk Sewer – Cleaning and televising of 15” sanitary sewer pipe to determine lining necessity and Cured-in-Place 15” sanitary sewer pipe from Manhole E18 to H5 for a total length of 1,737 L.F. (Sheet #4 of 7)
- Trunk Sewer from WWTP to south of State Route 571 – Cleaning and televising of 15” sanitary sewer pipe to determine lining necessity and Cured-in-Place 15” sanitary sewer pipe from Manhole H23 to H13 for a total length of 3,380 L.F. (Sheet #5 of 7)
- Manhole rehabilitation including manhole steps and joint grouting.
- Manhole casting with gasket replacement like East Jordan Assembly 211ZPT/211APT 7” tall gasketed casting with bolt down lid and stainless steel bolts as shown on the attached detail or approved equal.
- Various other incidental items to include point repairs, lateral replacements, protruding lateral cut-outs, maintaining traffic, and mobilization/demobilization.

2) The Alternate Bids in the original Bidding Documents have been renumbered for inclusion of the following Alternates:

- Alternate Bid #1 – 8” cured-in-place pipe on Carmel Drive from Manhole E1 to E6 for a total length of 905 L.F.
- Alternate Bid #2 – 8” cured-in-place pipe on Water Street from Manhole D23 to D21 for a total length of 335 L.F.
- Alternate Bid #3 – 8” cured-in-place pipe on Melvin Eley Avenue from Manhole D5 to E34 for a total length of 1,165 L.F.
- Alternate Bid #12 – Cleaning and televising of 15” sanitary sewer pipe to determine lining necessity and Cured-in-Place 15” sanitary sewer pipe from Manhole H5 to H13 for a total length of 3,074 L.F. (Sheet #5 of 7)

CHANGES/CLARIFICATIONS TO THE TECHNICAL SPECIFICATIONS:

4. CLEANING & TELEVISIONING OF SEWER PIPELINES, SECTION 33 01 30.16

A. An additional Bid Item for cleaning and televising of the 15” sanitary sewer has been added to the “Revised Bid Form” that references the attached specification Section 33 01 30.16. This sewer is suspected to be PVC and may require cleaning, but not lining.

CHANGES/CLARIFICATIONS TO THE CONSTRUCTION PLANS:

5. GENERAL NOTES, SHEET # 3 OF 7

A. Add Note #33 to the plans for “Sequence of Work” as follows:

33. Sequence of Work for 15” Sanitary Sewer

- 1) The Village will locate and excavate manholes along the 15” sanitary sewer that are not accessible from streets or alleys. This work shall not be included in this Contract. Contractor shall coordinate this schedule with Owner.
- 2) The Contractor shall clean and televise the 15” sanitary sewer to determine the need for cured-in-place lining of the existing pipe which is believed to be PVC (plastic).
- 3) The Contractor shall have any necessary point repairs completed as discovered during the cleaning and televising of the pipe to insure the appropriate integrity for accepting any CIPP.
- 4) The pipe shall be lined, as needed, per the televising results and as directed by the Engineer. The Engineer shall also provide direction in lining through manholes with no reinstatement of the inverts based on the field conditions and abilities of the Contractor.
- 5) Manhole rehabilitation along the 15” sanitary sewer will be conducted as directed by the Engineer based on existing conditions and to be paid based on Vertical Feet completed.
- 6) Any manholes that are excavated for pipe access or rehabilitation will be buried by the Owner. This work shall not be included in this Contract.

GENERAL CLARIFICATIONS

6. Driveway Entrance Access

The Owner shall provide driveway entrances from adjacent roadways to accommodate access to the trunk sewer. As noted on the plans, the Village has a 30’ easement based on the centerline of the pipe. This will be located by the Owner to facilitate work areas by Contractor.

7. Clearing & Grubbing

It shall be the Contractor’s responsibility to dispose of all clearing and grubbing debris that occurs during the course of the project.

End of Addendum

Attachments: Revised Bid Form, Section 00 41 43
Casting with Gasket Detail (East Jordan 211ZPT)
Cleaning & Televising of Sewer Pipelines, Section 33 01 30.16

BID FORM
00 41 43

ARTICLE 1 - BID RECIPIENT

- 1.01 This Bid is submitted to: **[Village of Union City, 419 Elm Street, Union City, OH 45390]**
- 1.02 The undersigned Bidder proposes and agrees, if this Bid is accepted, to enter into an Agreement with Owner in the form included in the Bidding Documents to perform all Work as specified or indicated in the Bidding Documents for the prices and within the times indicated in this Bid and in accordance with the other terms and conditions of the Bidding Documents.

ARTICLE 2 - BIDDER'S ACKNOWLEDGEMENTS

- 2.01 Bidder accepts all of the terms and conditions of the Instructions to Bidders, including without limitation those dealing with the disposition of Bid security. This Bid will remain subject to acceptance for 60 days after the Bid opening, or for such longer period of time that Bidder may agree to in writing upon request of Owner.

ARTICLE 3 - BIDDER'S REPRESENTATIONS

- 3.01 In submitting this Bid, Bidder represents that:
 - A. Bidder has examined and carefully studied the Bidding Documents, and any data and reference items identified in the Bidding Documents, and hereby acknowledges receipt of the following Addenda:

<u>Addendum No.</u>	<u>Addendum, Date</u>
_____	_____
_____	_____
_____	_____
 - B. Bidder has visited the Site, conducted a thorough, alert visual examination of the Site and adjacent areas, and become familiar with and satisfied itself as to the general, local, and Site conditions that may affect cost, progress, and performance of the Work.
 - C. Bidder is familiar with and has satisfied itself as to all Laws and Regulations that may affect cost, progress, and performance of the Work.
 - D. Bidder has carefully studied all: (1) reports of explorations and tests of subsurface conditions at or adjacent to the Site and all drawings of physical conditions relating to existing surface or subsurface structures at the Site that have been identified in the Supplementary Conditions, especially with respect to Technical Data in such reports and drawings, and (2) reports and drawings relating to Hazardous Environmental Conditions, if any, at or adjacent to the Site that have been identified in the Supplementary Conditions, especially with respect to Technical Data in such reports and drawings.
 - E. Bidder has considered the information known to Bidder itself; information commonly known to contractors doing business in the locality of the Site; information and observations obtained from visits to the Site; the Bidding Documents; and any Site-related reports and drawings identified in the Bidding Documents, with respect to the effect of such information, observations, and documents on (1) the cost, progress, and performance of the Work; (2) the means, methods,

techniques, sequences, and procedures of construction to be employed by Bidder; and (3) Bidder's safety precautions and programs.

- F. Bidder agrees, based on the information and observations referred to in the preceding paragraph, that no further examinations, investigations, explorations, tests, studies, or data are necessary for the determination of this Bid for performance of the Work at the price bid and within the times required, and in accordance with the other terms and conditions of the Bidding Documents.
- G. Bidder is aware of the general nature of work to be performed by Owner and others at the Site that relates to the Work as indicated in the Bidding Documents.
- H. Bidder has given Engineer written notice of all conflicts, errors, ambiguities, or discrepancies that Bidder has discovered in the Bidding Documents, and confirms that the written resolution thereof by Engineer is acceptable to Bidder.
- I. The Bidding Documents are generally sufficient to indicate and convey understanding of all terms and conditions for the performance and furnishing of the Work.
- J. The submission of this Bid constitutes an incontrovertible representation by Bidder that Bidder has complied with every requirement of this Article, and that without exception the Bid and all prices in the Bid are premised upon performing and furnishing the Work required by the Bidding Documents.
- K. Bidder agrees that the contracting authority reserves the right to reject any or all bids, to waive any informalities or irregularities in the bids received, and to accept that bid which is considered lowest and to the best interest of the Owner.

ARTICLE 4 - BIDDER'S CERTIFICATION

4.01 Bidder certifies that:

- A. This Bid is genuine and not made in the interest of or on behalf of any undisclosed individual or entity and is not submitted in conformity with any collusive agreement or rules of any group, association, organization, or corporation;
- B. Bidder has not directly or indirectly induced or solicited any other Bidder to submit a false or sham Bid;
- C. No person interested in this Proposal is directly or indirectly interested in or connected with any other bid or proposal for the said work and no member of the Village of Union City, Ohio, is directly or indirectly interested therein, or in any portion thereof, and he will, if required by the Village of Union City, Ohio, execute and submit from himself as Principal Contractor and from any Subcontractor, the non-collusion affidavits as provided herein.
- D. Bidder has not solicited or induced any individual or entity to refrain from bidding; and
- E. Bidder has not engaged in corrupt, fraudulent, collusive, or coercive practices in competing for the Contract. For the purposes of this Paragraph 4.01.D:
 - 1. "corrupt practice" means the offering, giving, receiving, or soliciting of anything of value likely to influence the action of a public official in the bidding process;
 - 2. "fraudulent practice" means an intentional misrepresentation of facts made (a) to influence the bidding process to the detriment of Owner, (b) to establish bid prices at artificial non-competitive levels, or (c) to deprive Owner of the benefits of free and open competition;

3. "collusive practice" means a scheme or arrangement between two or more Bidders, with or without the knowledge of Owner, a purpose of which is to establish bid prices at artificial, non-competitive levels; and
4. "coercive practice" means harming or threatening to harm, directly or indirectly, persons or their property to influence their participation in the bidding process or affect the execution of the Contract.

ARTICLE 5 - BASIS OF BID

- 5.01 Bidder agrees that any item not specifically shown or called out on the plans or within the specifications, but is required to complete the work in place and fully operational, shall be included in the bid item that is most closely associated with that portion of the work.
- 5.02 Bidder will complete the Work in accordance with the Contract Documents for the following price(s) and will contract to do all the work and furnish all the materials called for by said plans and specifications, and in consideration thereof, to accept from the Owner as full payment for the completion of each specified item and any required maintenance thereof as hereinafter provided, for the following prices;

BASE BID – SANITARY SEWER REHABILITATION PHASE V

Item No.	Description	Est. Qty.	Unit	Unit Price	Total Unit Price
614	Maintaining Traffic	1	Lump		
624	Mobilization/Demobilization	1	Lump		
00 79 20	Manhole Joint Grouting per Structure	13	Each		
33 01 03	12" Point Repair < 10'	1	Each		
33 01 03	12" Point Repair, 10' – 15'	1	Each		
33 01 03	12" Point Repair, > 15'	1	Each		
33 01 03	15" Point Repair < 10'	1	Each		
33 01 03	15" Point Repair, 10' – 15'	1	Each		
33 01 03	15" Point Repair, > 15'	1	Each		
33 01 03	4"-6" Lateral Replacement < 10'	1	Each		
33 01 03	4"-6" Lateral Replacement 10' – 15'	1	Each		
33 01 03	4"-6" Lateral Replacement > 15'	1	Each		
33 01 30.16	Cleaning & Televising of 15" Sewer	5,117	L.F.		
33 01 30.62	Manhole Rehabilitation	255	V.F.		
33 01 30.62	Manhole Steps	40	Each		
Special	Manhole Casting with Gasket	8	Each		
33 01 30.72	12" Cured-in-Place Pipe	1,507	L.F.		

BASE BID – SANITARY SEWER REHABILITATION PHASE V (continued)

Item No.	Description	Est. Qty.	Unit	Unit Price	Total Unit Price
33 01 30.72	15" Cured-in-Place Pipe	5,117	L.F.		
33 01 30.72	Protruding Lateral Cut-Out	10	Each		
Total Base Bid:					

Total Base Bid (in words):

ALTERNATE BID #1 – SANITARY SEWER REHABILITATION (Carmel Drive)

Item No.	Description	Est. Qty.	Unit	Unit Price	Total Unit Price
33 01 03	8" Point Repair < 10'	1	Each		
33 01 03	8" Point Repair, 10' – 15'	1	Each		
33 01 03	8" Point Repair > 15'	1	Each		
33 01 30.72	8" Cured-in-Place Pipe (E1 through E6) on Carmel Drive	905	L.F.		
Total Alternate Bid #1:					

Total Alternate Bid #1 (in words):

ALTERNATE BID #2 – SANITARY SEWER REHABILITATION PHASE V (Water Street)

Item No.	Description	Est. Qty.	Unit	Unit Price	Total Unit Price
33 01 30.72	8" Cured-in-Place Pipe (D23 through D21) on Water Street	335	L.F.		
Total Alternate Bid #2:					

Total Alternate Bid #2 (in words):

ALTERNATE BID #3 – SANITARY SEWER REHABILITATION PHASE V (Melvin Eley Avenue)

Item No.	Description	Est. Qty.	Unit	Unit Price	Total Unit Price
33 01 30.72	8" Cured-in-Place Pipe (D5 through D34) on Melvin Eley Avenue	1,165	L.F.		
Total Alternate Bid #3:					

Total Alternate Bid #3 (in words):

ALTERNATE BID #4 – SANITARY SEWER REHABILITATION PHASE V (Alley)

Item No.	Description	Est. Qty.	Unit	Unit Price	Total Unit Price
33 01 30.72	8" Cured-in-Place Pipe (D14 through D18) in Alley intersecting Main & Water	400	L.F.		
Total Alternate Bid #4:					

Total Alternate Bid #4 (in words):

ALTERNATE BID #5 – SANITARY SEWER REHABILITATION PHASE V (Main Street)

Item No.	Description	Est. Qty.	Unit	Unit Price	Total Unit Price
33 01 30.72	8" Cured-in-Place Pipe (D13 through D35) on Main Street	679	L.F.		
Total Alternate Bid #5:					

Total Alternate Bid #5 (in words):

ALTERNATE BID #6 – SANITARY SEWER REHABILITATION PHASE V (Alley)

Item No.	Description	Est. Qty.	Unit	Unit Price	Total Unit Price
33 01 30.72	8" Cured-in-Place Pipe (F15 through D18) in Alley intersecting Chestnut St.	592	L.F.		
Total Alternate Bid #6:					

Total Alternate Bid #6 (in words):

ALTERNATE BID #7 – SANITARY SEWER REHABILITATION PHASE V (Ward Street)

Item No.	Description	Est. Qty.	Unit	Unit Price	Total Unit Price
33 01 30.72	8" Cured-in-Place Pipe (C3 through C2) on Ward Street	495	L.F.		
Total Alternate Bid #7:					

Total Alternate Bid #7 (in words):

ALTERNATE BID #8 – SANITARY SEWER REHABILITATION PHASE V (John Street)

Item No.	Description	Est. Qty.	Unit	Unit Price	Total Unit Price
33 01 30.72	8" Cured-in-Place Pipe (C2 to C4) on John Street	360	L.F.		
Total Alternate Bid #8:					

Total Alternate Bid #8 (in words):

ALTERNATE BID #9 – SANITARY SEWER REHABILITATION PHASE V (Alley)

Item No.	Description	Est. Qty.	Unit	Unit Price	Total Unit Price
33 01 30.72	8" Cured-in-Place Pipe (C1 through LH) in Alley intersecting Ward Street	425	L.F.		
Total Alternate Bid #9:					

Total Alternate Bid #9 (in words):

ALTERNATE BID #10 – SANITARY SEWER REHABILITATION PHASE V

Item No.	Description	Est. Qty.	Unit	Unit Price	Total Unit Price
Special	Internal Manhole Drop, As Per Plan	1	Each		
Total Alternate Bid #10:					

Total Alternate Bid #10 (in words):

ALTERNATE BID #11 – SANITARY SEWER REHABILITATION PHASE V

Item No.	Description	Est. Qty.	Unit	Unit Price	Total Unit Price
Special	Chimney Seal	1	Each		
Total Alternate Bid #11:					

Total Alternate Bid #11 (in words):

ALTERNATE BID #12 – SANITARY SEWER REHABILITATION PHASE V

Item No.	Description	Est. Qty.	Unit	Unit Price	Total Unit Price
33 01 30.72	Cleaning & Televising	3,074	L.F.		
00 79 20	Manhole Joint Grouting per Structure	7	Each		
33 01 30.72	15" Cured-in-Place Pipe (H5 through H13) the Trunk Sewer	3,074	L.F.		
33 01 30.62	Manhole Rehabilitation	55	V.F.		
33 01 30.62	Manhole Steps	40	Each		
Total Alternate Bid #8:					

Total Alternate Bid #12 (in words):

5.03 Bidder acknowledges that:

- (1) Each Bid Unit Price includes an amount considered by Bidder to be adequate to cover Contractor's overhead and profit for each separately identified item;
- (2) Estimated quantities are not guaranteed, and are solely for the purpose of comparison of Bids, and final payment for all unit price Bid items will be based on actual quantities, determined as provided in the Contract Documents; and
- (3) The Owner reserves the right to add or delete such quantities within the scope of the project as deemed necessary without in any way invalidating the Unit Prices bid.
- (4) If this Proposal shall be accepted, Bidder will be prepared to discuss with the Owner in detail any matters relating to special features and the methods proposed to be followed for the general conduct of the work, that within ten (10) days after "Notice of Award" the Contract Form with the Village of Union City for performance of the work will be completed and Bidder will furnish a Contract Bond or a Performance and Payment Bond in an amount not less than one hundred percent (100%) of the total bid amount, and with sureties subject to the approval of the Village of Union City as a guarantee of the faithful performance of this Contract; and that Bidder will also submit the required insurance policies.

ARTICLE 6 - TIME OF COMPLETION

- 6.01 Bidder agrees that the Work will be substantially complete and ready for final payment in accordance with Paragraph 15.06 of the General Conditions on or before **December 31, 2020.**
- 6.02 Bidder accepts the provisions of the Agreement as to liquidated damages in the amount of \$500.00 for every consecutive day after the stated date in the Notice to Proceed and along with any time extension given per a Change Order and it may be retained from the monies which may be due.

ARTICLE 7 - ATTACHMENTS TO THIS BID

7.01 The following documents are submitted with and made a condition of this Bid:

- A. Required bid security;
- B. Affidavit for Corporation;
- C. Required Bidder Qualification Statement with supporting data;
- D. List of Proposed Subcontractors;
- E. Non-Collusion Affidavit; and
- F. Certifications as listed in Section 3—Procurement Forms & Supplements in the Table of Contents.

ARTICLE 8 - DEFINED TERMS

8.01 The terms used in this Bid with initial capital letters have the meanings stated in the Instructions to Bidders, the General Conditions, and the Supplementary Conditions.

ARTICLE 9 - BID SUBMITTAL

BIDDER:[Indicate correct name of bidding entity]

By: *[Signature]* _____

[Printed name] _____

(If Bidder is a corporation, limited liability company, partnership or joint venture, attach evidence of authority to sign.)

Address for giving notices:

Telephone Number: _____ Fax Number: _____

Bidder's Federal ID No.: _____ Date: _____

Contact Name and e-mail address: _____

2111ZPT 2111APT Assembly

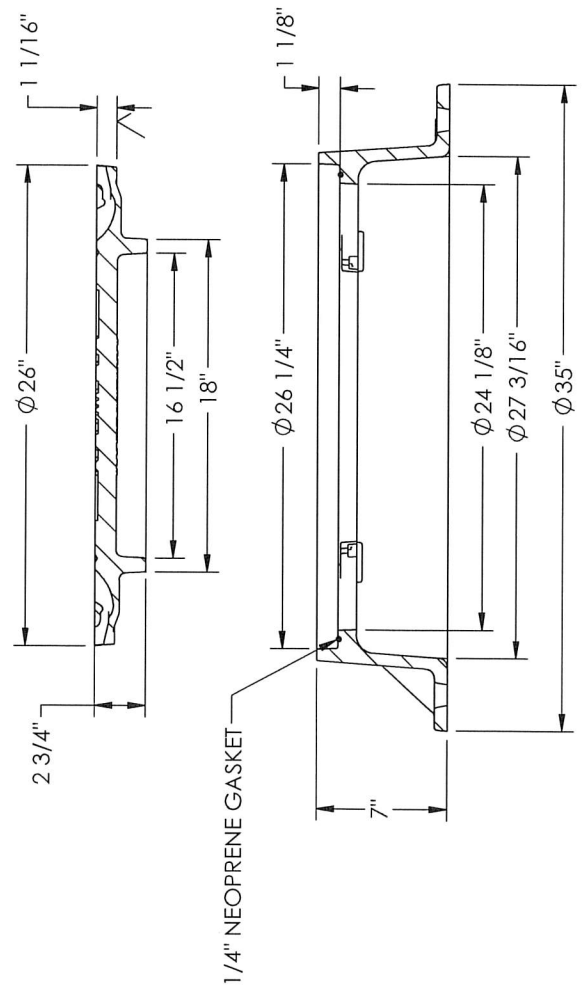
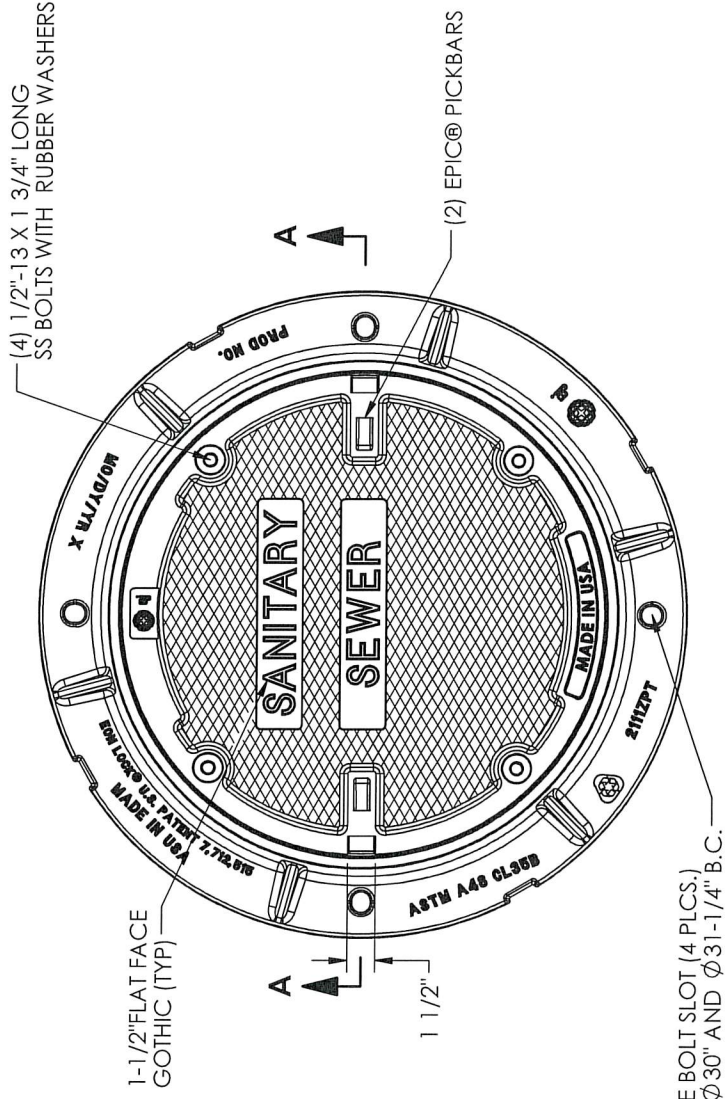

Product Number
00211174W01

Design Features
-Materials
Frame
Gray Iron (CL35B)
Cover
Gray Iron (CL35B)

-Design Load
Heavy Duty
-Open Area
n/a
-Coating
Undipped
-√ Designates Machined Surface

Certification
-ASTM A48

-Country of Origin: USA

Major Components
00211119
00211174

Drawing Revision
4/5/2017 Designer: TK
10/2/2018 Revised By: MAH

Disclaimer
Weights (lbs/kg), dimensions (inches/mm) and drawings provided for your guidance. We reserve the right to modify specifications without prior notice.

CONFIDENTIAL: This drawing is the property of EJ Group, Inc. and embodies confidential information, registered marks, patents, trade secret information, and/or know-how that is the property of EJ Group, Inc. Copyright © 2013 EJ Group, Inc. All rights reserved.

Contact
800 626 4653
ejco.com

CLEANING & TELEVISIONING OF SEWER PIPELINES
33 01 30.16

PART ONE – GENERAL

1.01 Requirements Included

- A. Pipeline flushing and cleaning.
- B. TV inspection of sewer pipelines.
- C. Audio-video recording of pipeline interior.
- D. Related Section: Section 33 31 03 Placement of Sanitary Utility Sewerage Piping

1.02 References:

- A. Electronics Industries Association (EIA).

1.03 Submittals

- A. Section 01 33 00 – Submittal Procedures: Requirements for submittals.
- B. Submit completed video media, identified by media number, project name, street name, right-of-way property name, and manhole numbers.
- C. Video media becomes property of Owner.
- D. Submit cleaning and television inspection logs for each section of sewer line to be rehabilitated and three copies of color video media for work performed. Include the following as minimum information: stationing and location of lateral services, wyes or tees, clock references, pipe joints, infiltration/inflow defects, cracks, leaks, offset joints, and other information required to assess condition of sewer.
- E. Submit a specific, detailed description of proposed bypass pumping system to include written description of plan and addressing quantity, capacity, and location of pumping equipment. Submit spill plan to address any spills that might occur.

1.04 Quality Assurance

- A. Perform work in accordance with local agency having jurisdiction.
- B. Use cameras with video output capable of producing minimum of 600 lines of horizontal resolution at center; optimum imagery with minimum illumination; and meet requirements of EIA Standard Video Signal.

1.05 Qualifications

- A. Applicator: Company specializing in performing work of this Section with minimum three years documented experience.

PART TWO – PRODUCTS

2.01 DVD

- A. Audio track containing simultaneously recorded narrative commentary and evaluations of operator describing, in detail, condition of pipeline interior.

PART THREE – EXECUTION

3.01 Preparation

- A. Flush and clean pipeline interiors to remove sludge, dirt, sand, stone, grease, and other materials from pipe to ensure clear view of interior conditions.
- B. Intercept flushed debris at next downstream manhole by use of weir or screening device; remove blockages and restrictions with waste to be disposed of at the Village Wastewater Treatment Plant.
- C. Furnish materials, labor, equipment, power, and maintenance to implement a temporary bypass pumping system around work area for time required to complete TV inspection.
- D. Furnish all necessary and required traffic control.
- E. Enforce all safety requirements for employers, public, and equipment during cleaning operations.

3.02 Application

- A. Closed Circuit TV Camera System:
 - 1. Utilize cameras specifically designed and constructed for closed-circuit sewer line inspection. Utilize camera equipment with pan and tilt capability to view each lateral connection at multiple angles.
 - 2. Utilize camera capable of moving upstream and downstream; minimum 1,000 feet horizontal distance with one setup; direct reading cable position meter.
 - 3. The work shall include all those measures required for sewer line cleaning and inspection including removal of sludge, dirt, sand, rocks, grease, roots and any other foreign materials from gravity sewer lines such that 95% of the cross sectional area of the sewer is not occluded by foreign materials at any location.

3.03 Field Quality Control

A. Pipeline Inspection:

1. Audio-video sections of sewer pipeline between manholes designated.
2. Identify and record locations of flat grades, dips, deflected joints, open joints, broken pipe, protrusions into pipelines, and points of infiltration.
3. Locate and record service connections.
4. Record locations of pipeline defects and connection horizontal distance, in feet, and direction from manholes.
5. Video with pipe section plugged as to view 100 percent of inside pipe diameter; use flow control methods as specified for bypass pumping system to eliminate surcharging and reduce flow.

End of Section